

Service Cart Assembly Instructions

Read entire instruction sheet prior to assembly of unit.

* 7520 - 4520
4577 - 4578

Components

16"x30" Qty.		Component	24"x36" Qty.		Component
1		Top Shelf	1		Top Shelf
1		Bottom Shelf	1		Bottom Shelf
2		5" Swivel Casters	2		5" Swivel Casters
2		5" Rigid Casters	2		5" Rigid Casters
*16		5/16" - 18 x 1 1/4" Truss Head Screws	*16		5/16" - 18 x 1 1/4" Truss Head Screws
*16		5/16" Lock Washers	*16		5/16" Lock Washers
*16		5/16" Hex Nuts	*16		5/16" Hex Nuts
4		1/4" - 14 x 1" Self Tapping Screws	4		1/4" - 14 x 1" Self Tapping Screws
1		Middle Shelf (Optional)	1		Middle Shelf (Optional)

Tools Recommended: Screw Driver, Adjustable Wrench, Mallet, Ratchet with 3/8" Deep Well, and 1/2" regular sockets.

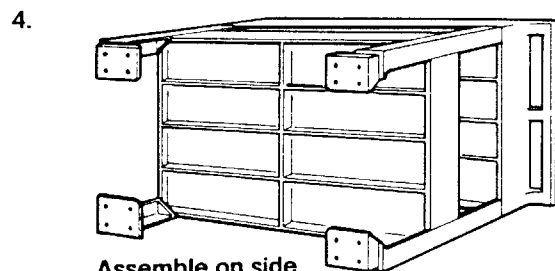
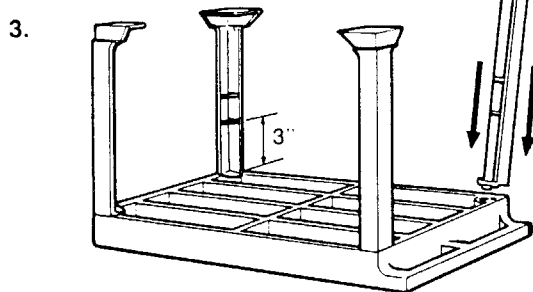
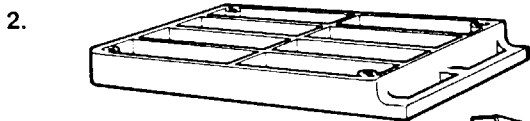
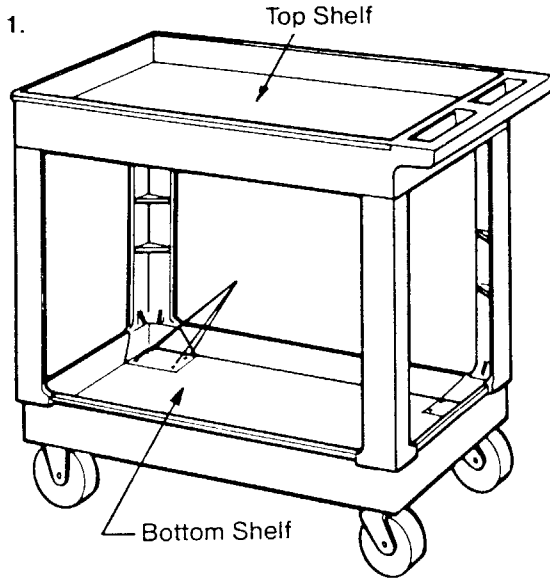

Assemble on side if installing middle shelf.

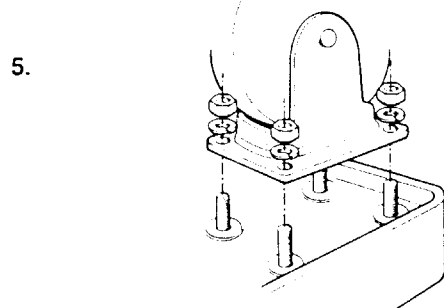

Assembly Procedures

1. Check to make sure you have required components (if missing components, see your RCP representative). **Read entire instruction sheet prior to assembly of unit.**

2. Place top shelf on floor with bottom of shelf facing up.

3. Insert four uprights (Long side of "L" upright aligns with long side of shelf) into socket areas in corner—lightly tap uprights with mallet until upright is seated against shelf. (4 1/4" - 14 x 1" self-tapping screws provided—when a permanent installation of top shelf is wanted or required; align screws with boss details at uprights.)

* If middle shelf is used, locate two uprights as described above, insert middle shelf between triangular shaped locators on uprights and set unit on its side prior to adding additional two uprights; tap uprights into place.

* If middle shelf is not used, locate uprights as described above and lay unit on its side and proceed to step 4.

4. Locate uprights into recesses on bottom shelf.

5. Mount casters; insert screw from top side of bottom shelf. Recommend that swivel casters be placed at handle end. Be sure to tighten nuts until they seat against caster plates.

6. Raise unit onto casters—unit is ready for action.

NOTE: Weight capacity is 200 pounds for each shelf—400 pounds total.